

INSTRUCTIONS:

1. Insert the bare terminal on the yellow wire into the mating accessory connector as shown below, then plug that connector back into the dash harness accessory connection.
2. Plug the power top harness into the motor connection and into the power top switch.
3. Remove the 30A fuse from the "BAT 2" location in the fuse panel and replace it with the provided 30 A circuit breaker. This breaker will need to be trimmed as shown below, before inserting.

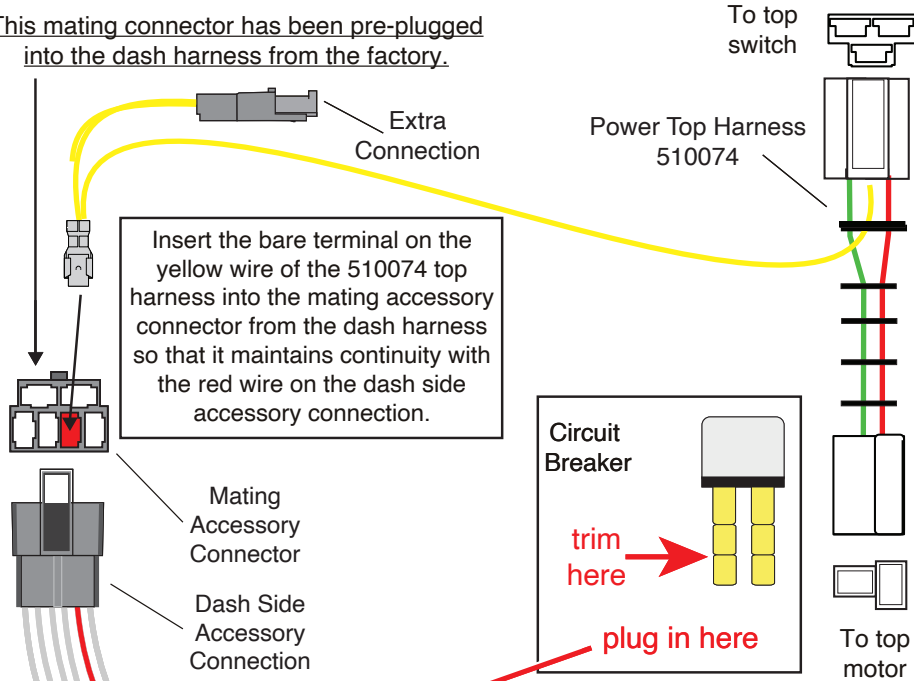

This mating connector has been pre-plugged into the dash harness from the factory.



PART # **510074**
 DESCRIPTION:
POWER TOP KIT
 1961-1962 Impala
 Classic Update Series
 92968976 Instruction Sheet rev 1.0 5/29/2024

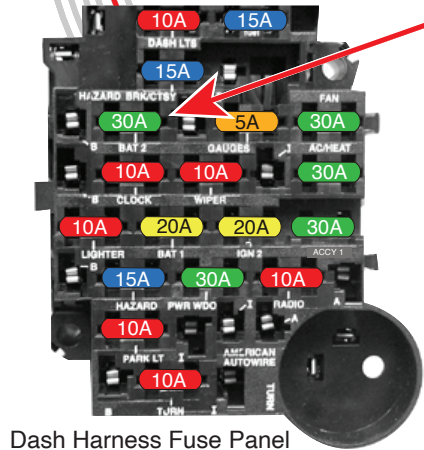

INSTRUCTIONS:

1. Insert the bare terminal on the yellow wire into the mating accessory connector as shown below, then plug that connector back into the dash harness accessory connection.
2. Plug the power top harness into the motor connection and into the power top switch.
3. Remove the 30A fuse from the "BAT 2" location in the fuse panel and replace it with the provided 30 A circuit breaker. This breaker will need to be trimmed as shown below, before inserting.



This mating connector has been pre-plugged into the dash harness from the factory.

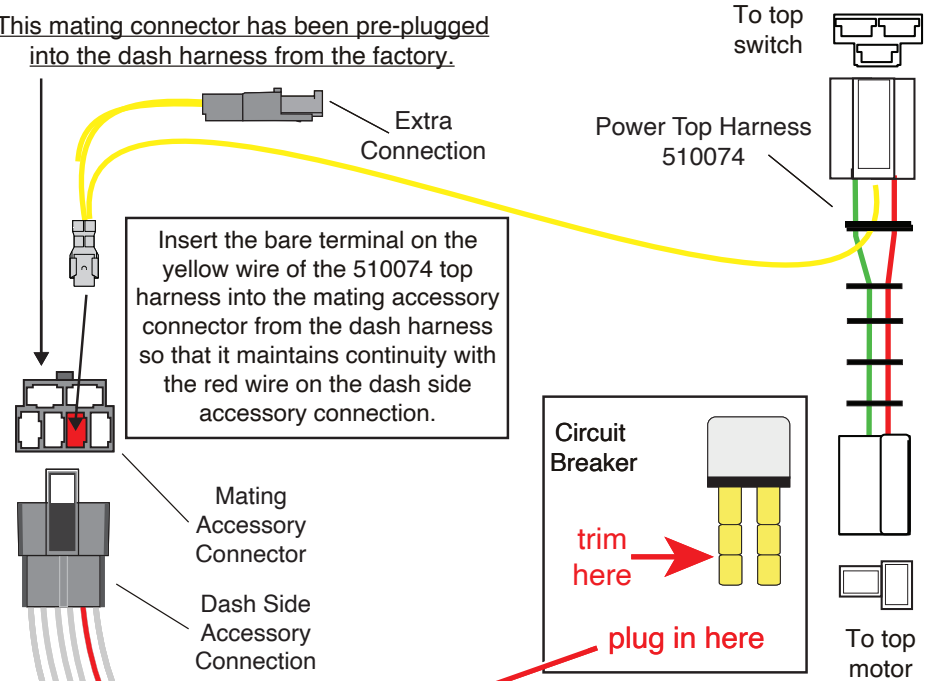

PART # **510074**
 DESCRIPTION:
POWER TOP KIT
 1961-1962 Impala
 Classic Update Series
 92968976 Instruction Sheet rev 1.0 5/29/2024

